

# DC Motors

D4566-3559

Issue 02

# Rotalink

Miniature Motors, Transmission and Control

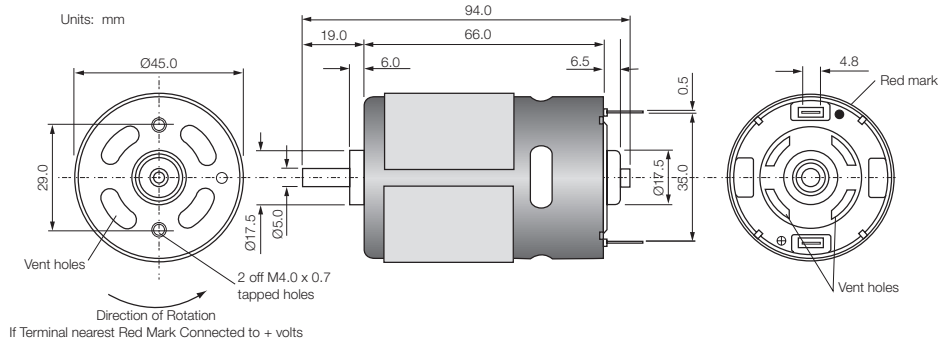

Model Number	Performance									
	Volts V	No Load		Maximum Efficiency				Stall		Max Power W
		Speed rpm	Current A	Speed rpm	Current A	Torque mNm	Output W	Torque mNm	Current A	
D4566-3559	24	6700	0.57	6150	1.60	37.5	24.1	409.0	15.53	66.6

Performance characteristics and general specification are measured from sample motor.

## Characteristics

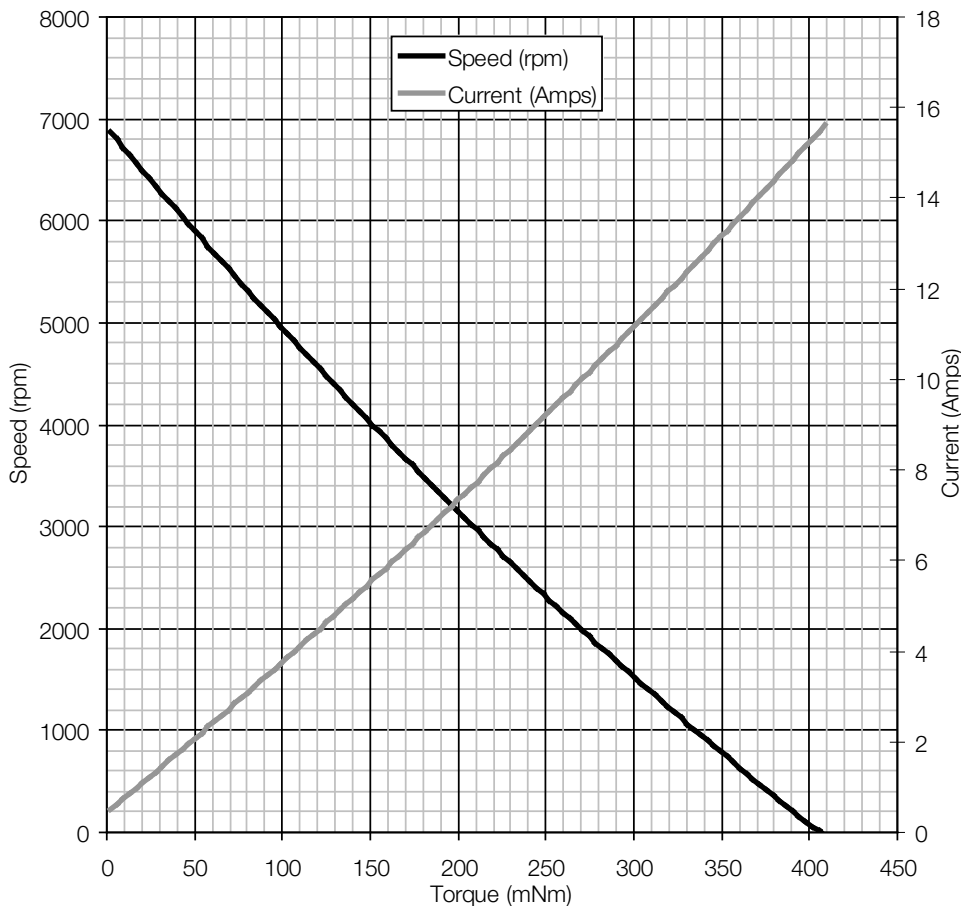

## General Specification

Bearings	Sintered
Brushes	Carbon
Rotation	Bi-directional
Number of poles	5
Operating voltage	12 V to 30 V
Nominal resistance	1.6 Ω
Typical detent torque	24 mNm
Suppression	None
Weight	360 g

### Contact:

www.rotalink.com  
 info@rotalink.com  
 T: +44 (0)1460 72000  
 F: +44 (0)1460 74278

Rotalink Limited  
 Cropmead, Crewkerne  
 Somerset TA18 7HQ, UK

www.rotalink.com