

# DC Motors

D4566-4050

Issue 01

# Rotalink

Miniature Motors, Transmission and Control

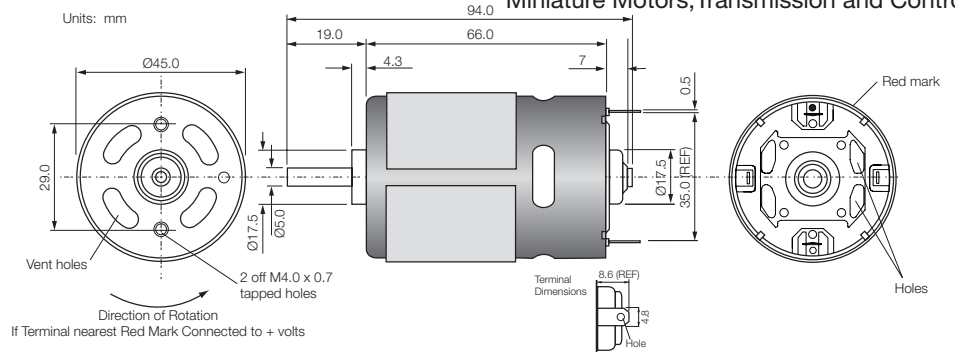

Model Number	Performance									
	Volts V	No Load		Maximum Efficiency				Stall		Max Power W
		Speed rpm	Current A	Speed rpm	Current A	Torque mNm	Output W	Torque mNm	Current A	
D4566-4050	24	7570	0.31	6347	3.26	72.9	48.4	510.0	19.0	101.0

Performance characteristics and general specification are measured from sample motor.

## Characteristics

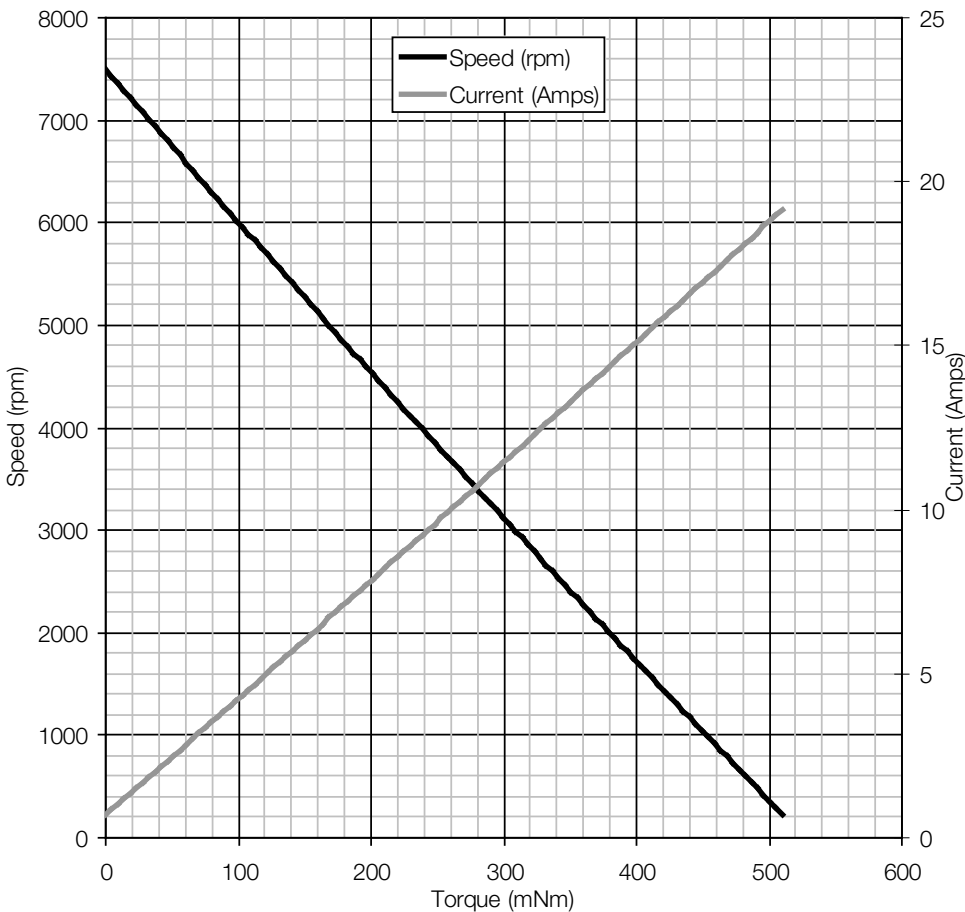

## General Specification

Bearings	Sintered
Brushes	Carbon
Rotation	Bi-directional
Number of poles	5
Operating voltage	12 V to 24 V
Nominal resistance	2 Ω
Typical detent torque	16 mNm
Suppression	Internal ring varistor
Weight	370 g

## Contact:

www.rotalink.com  
 info@rotalink.com  
 T: +44 (0)1460 72000  
 F: +44 (0)1460 74278

Rotalink Limited  
 Cropmead, Crewkerne  
 Somerset TA18 7HQ, UK

www.rotalink.com