

Cam Timers

HSMP/2

Issue 02

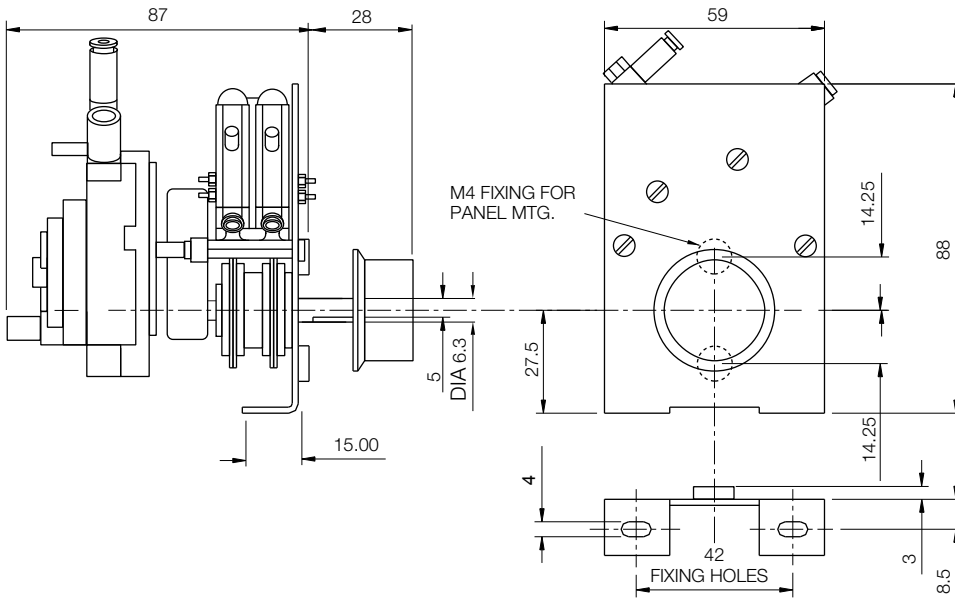

General Specification

Pneumatic Valve: Two x 3 Port, Poppet Valve
Valve and Motor: 4mm O.D. Push on

Standard HSMP/2 Pneumatic Cam Timers are fitted with two (2) adjustable cams. Each cam may be programmed to provide one valve operation per cycle.

Ordering Information

Model: HSMP/2
Speed:
Operating Pressure:

Eg: HSMP/2, 10 minutes, 70psi

Rotalink's HSMP/2 Pneumatic Cam Timers are available in any combination of the following cycle times and working pressures.

Cycle times and drive method	
Minutes per cycle	1, 4, 10.
Pneumatic Motor	25 to 100 psi

Contact:
www.rotalink.com
info@rotalink.com
T: +44 (0)1460 72000
F: +44 (0)1460 74278

Rotalink Limited
Cropmead, Crewkerne
Somerset TA18 7HQ, UK

www.rotalink.com