

Cam Timers

PN63

Issue 04

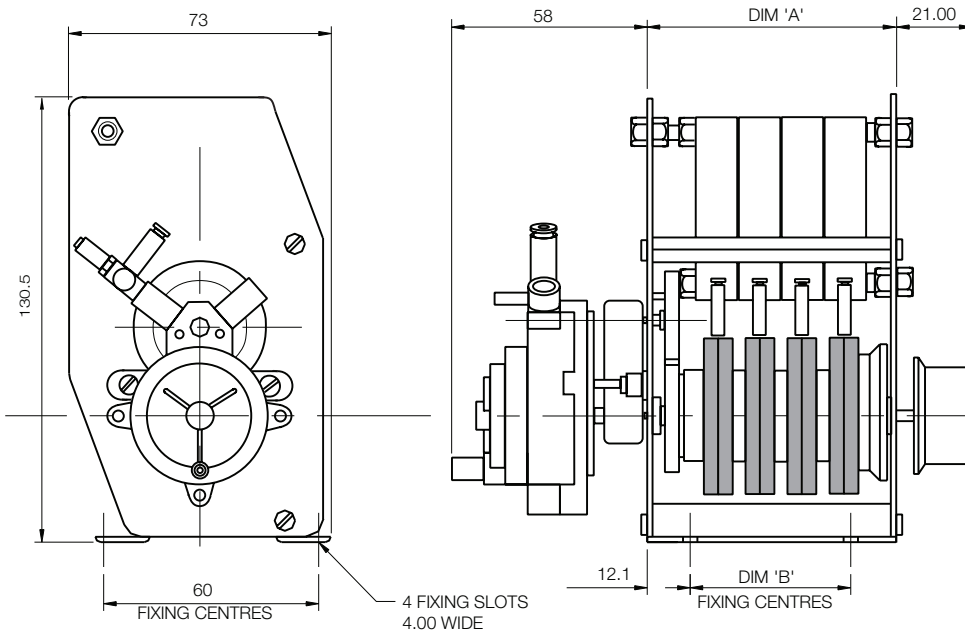

Number of Valves	Dim A	Dim B
2	63.2	38.8
4	103.2	78.8
5	123.2	98.8

General Specification

Motor connections:
 Pneumatic: 4mm Push on
 Electric: 1/4" Spade terminal
 Pneumatic Valve: Model KV1643
 Lever activated
 spool valve 3/2
 normally closed
 Valve connection: 6mm Push in fitting

Standard PN Pneumatic Cam Timers are fitted with adjustable cams. Each cam may be programmed to provide one valve operation per cycle.

Ordering Information

Model: PN63
 Number of valves
 Speed
 Drive method/operating pressure or electrical supply:

Eg: PN63/2, 4 minutes, 70psi

Rotalink's PN Pneumatic Cam Timers are available in any combination of the following cycle times, number of channels (valves) and drive methods.

Cycle times, drive methods and channels available	
Minutes per cycle	4, 8, 10, 20
Pneumatic Motor	25 to 100 psi
Electric Motor	Electrical Supply 110V, 240V - 50/60Hz
Number of channels (switches)	2, 4, 5

Contact:

www.rotalink.com
 info@rotalink.com
 T: +44 (0)1460 72000
 F: +44 (0)1460 74278

Rotalink Limited
 Cropmead, Crewkerne
 Somerset TA18 7HQ, UK

www.rotalink.com